

Item No.	Assembly Name
APC-S044	S-8080D Switch4 (GRY) 3m/1P+SB (L=266)

※Attached:S-BOX Support Bracket <D4R-001B>

1	C1S-712G	Pushbutton Switch (Lighted)	A22L-CG-24A-10M
2	C1S-712R	Pushbutton Switch (Lighted)	A22L-CR-24A-10M
3	C1S-712Y	Pushbutton Switch (Lighted)	A22L-CY-24A-10M
4	C1S-710R	Emergency Stop Switch (Lighted)	A22EL-M-24A-02

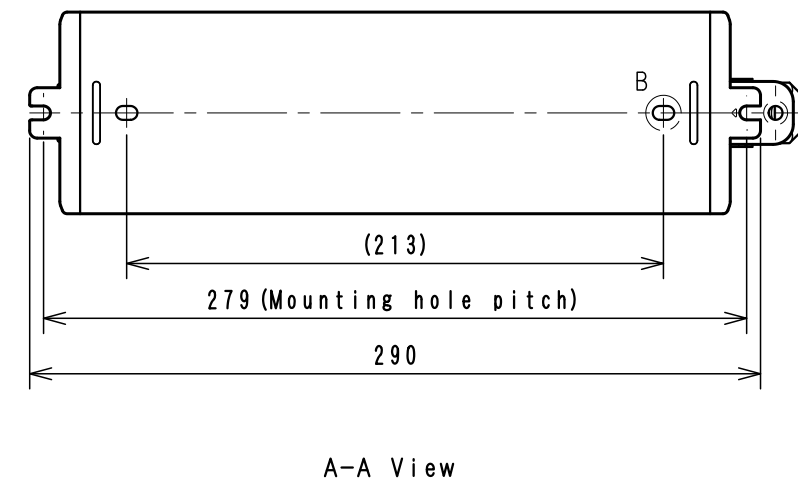
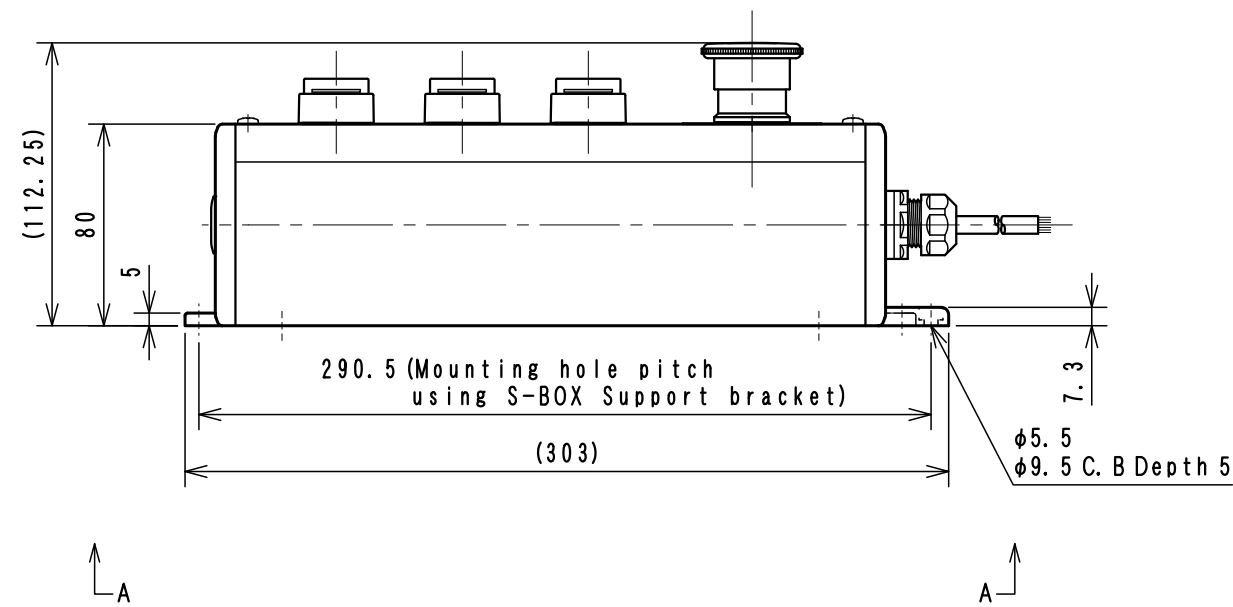
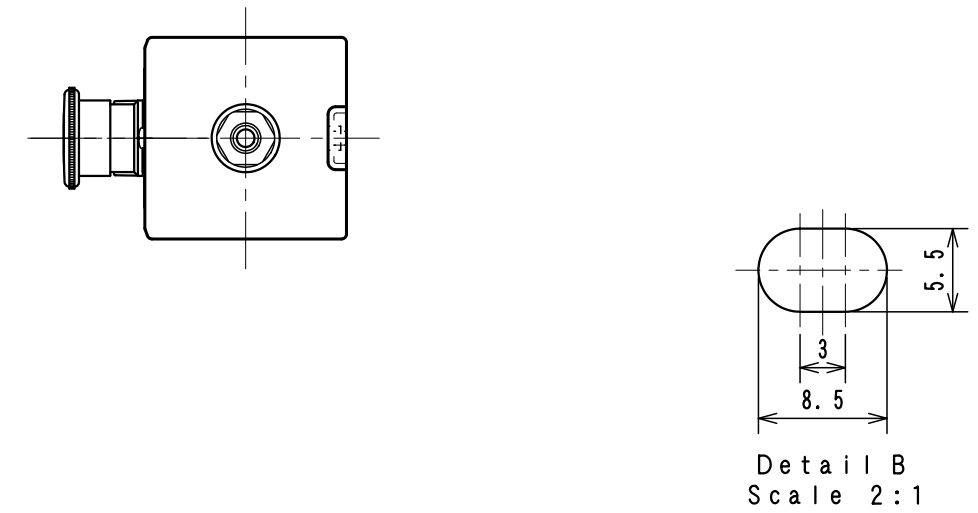
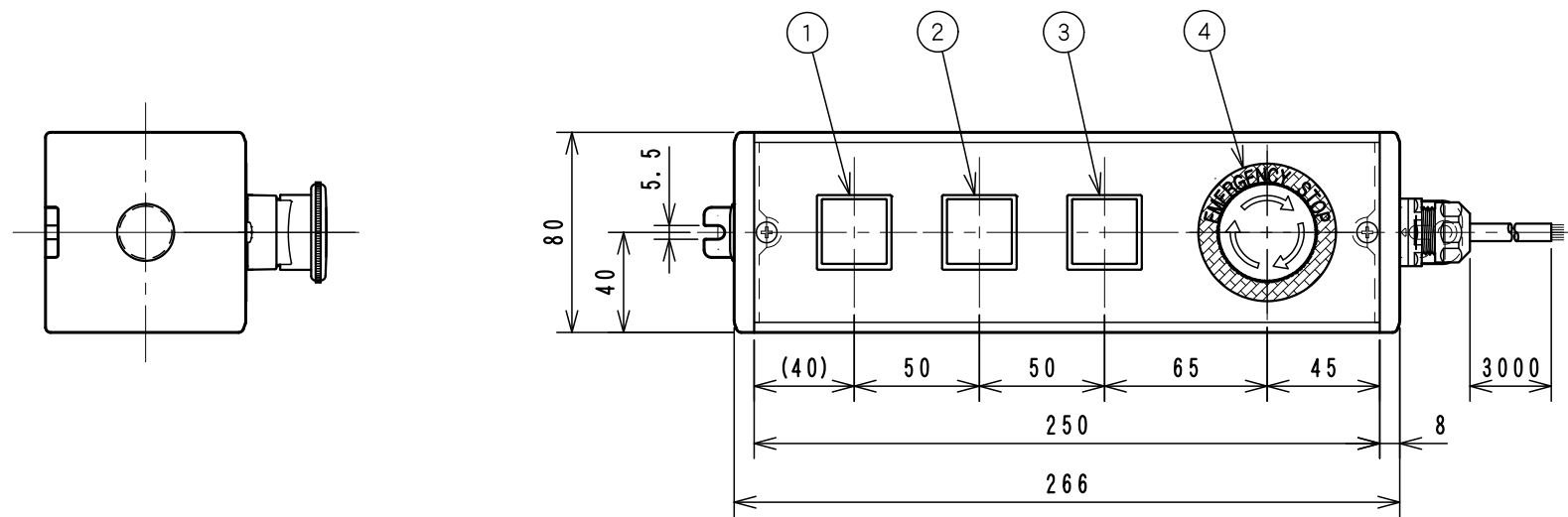

<Associated drawings>
WCW000708-01

Applicable Item No.	APC-S044
---------------------	----------

No.	Switch Model No.	Item No.
1	A22L-CG-24A-10M	C1S-712G
2	A22L-CR-24A-10M	C1S-712R
3	A22L-CY-24A-10M	C1S-712Y
4	A22EL-M-24A-02	C1S-710R

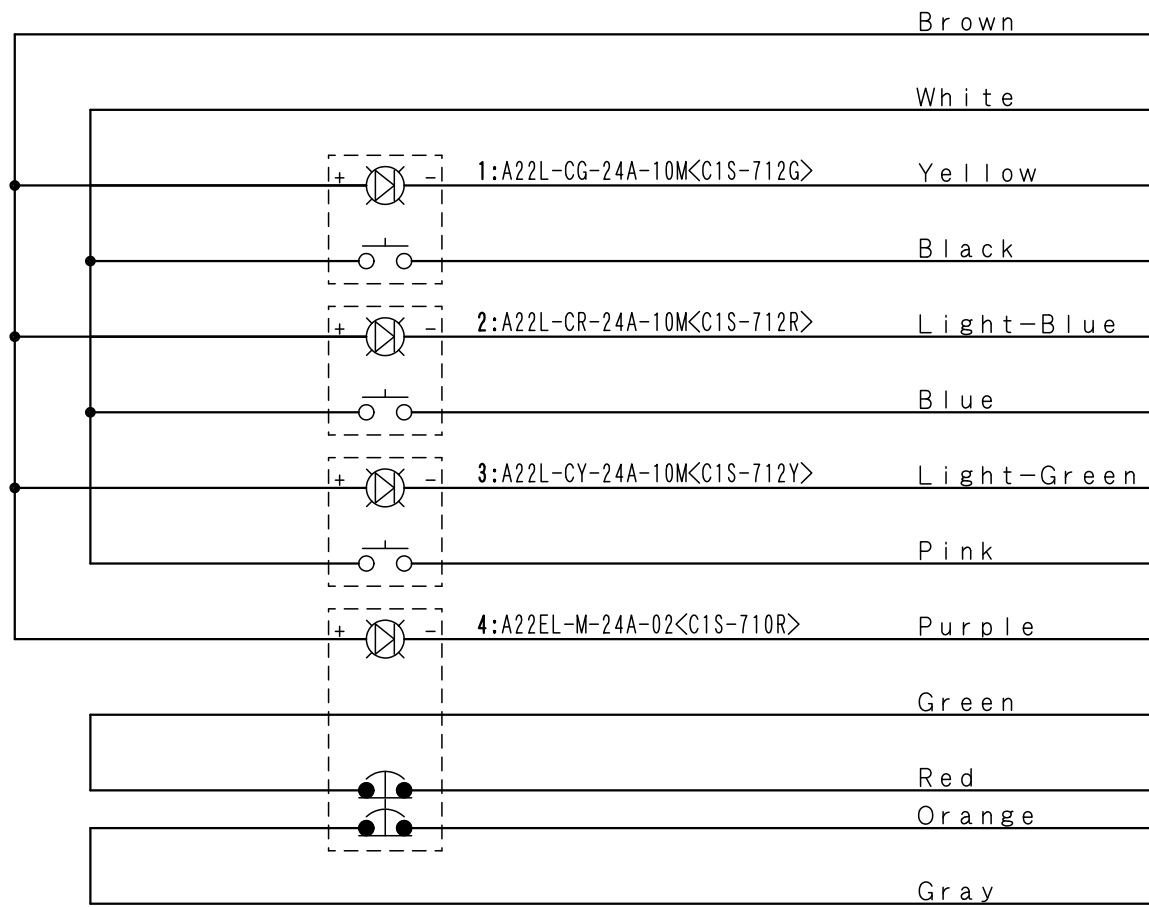

Cable processing detail

