

Item No.	Assembly Name
NJC-325	S-5057D Switch 3S (GRY) 1m/1P+SB

※Attached:S-BOX Support Bracket <D4R-001B>

1	C1S-761G	Pushbutton Switch(Lighted)	AR16G0N-C1E3G
2	C1S-761R	Pushbutton Switch(Lighted)	AR16G0N-C1E3R
3	C1S-761Y	Pushbutton Switch(Lighted)	AR16G0N-C1E3Y

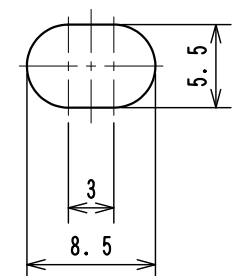
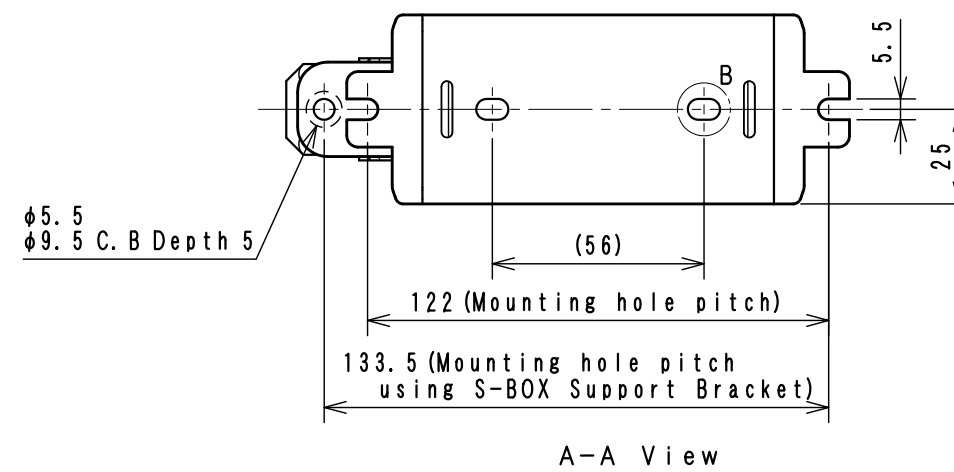
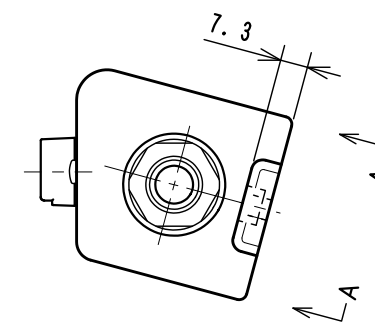
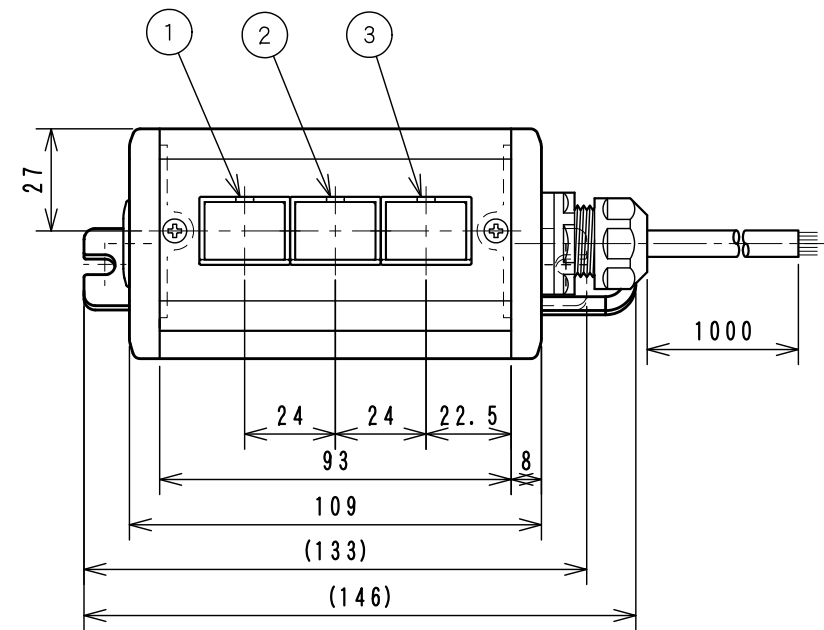
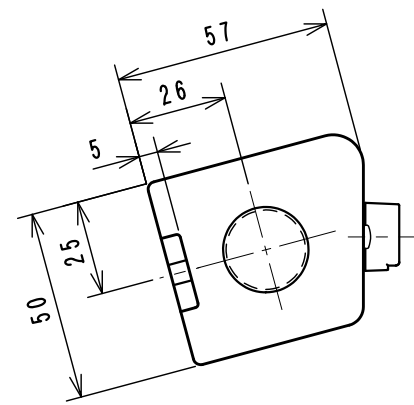

Detail B
Scale 2:1
2 Places

<Associated drawings>
WCW000518-01

Applicable Item No.	NJC-315
	NJC-325

No.	Switch Model No.	Item No.
1	AR16G0N-C1E3G	C1S-761G
2	AR16G0N-C1E3R	C1S-761R
3	AR16G0N-C1E3Y	C1S-761Y

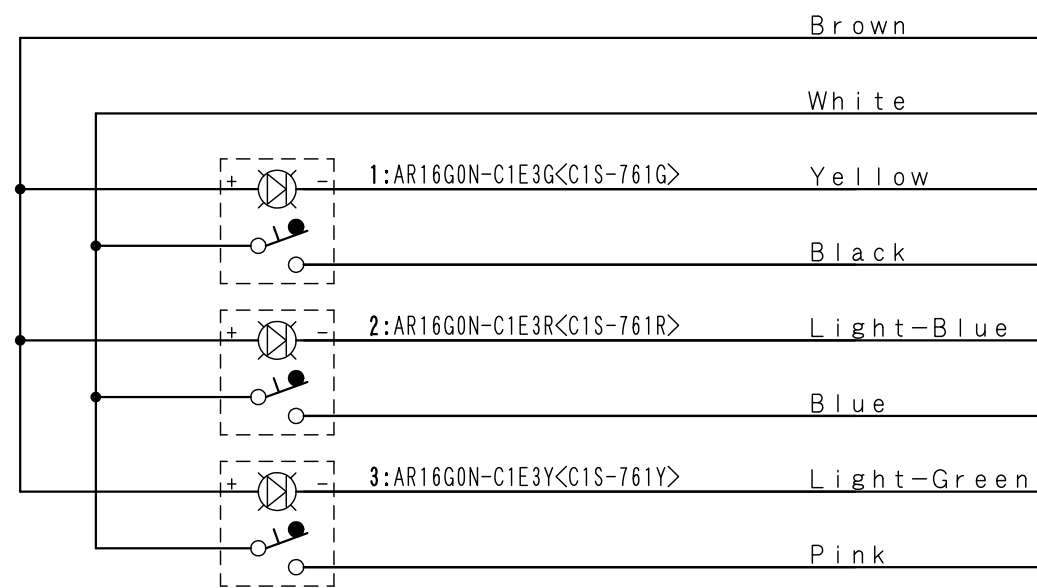

Cable processing detail

