

Item No.	Assembly Name
NLC-126	S-5057D Switch 1S (G) /1m 1P+SB

※Attached: S-BOX Support Bracket <D4R-001B>

1	C1S-763G	Pushbutton Switch AR16G0T-C1G
---	----------	-------------------------------

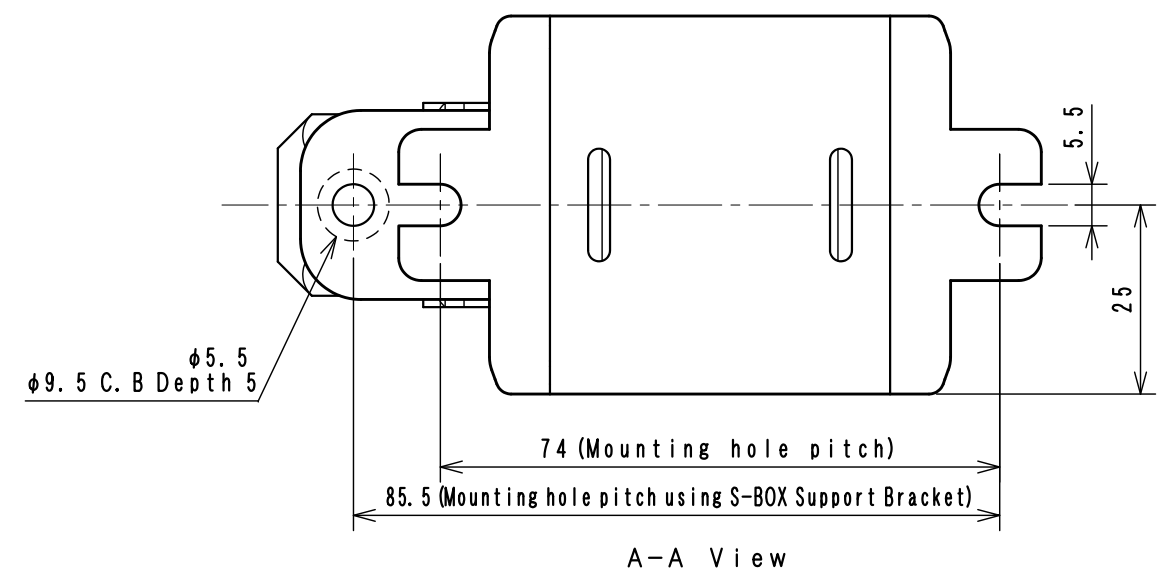
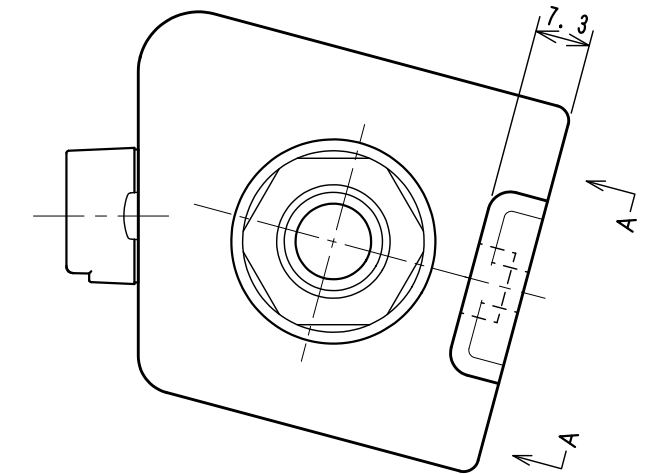
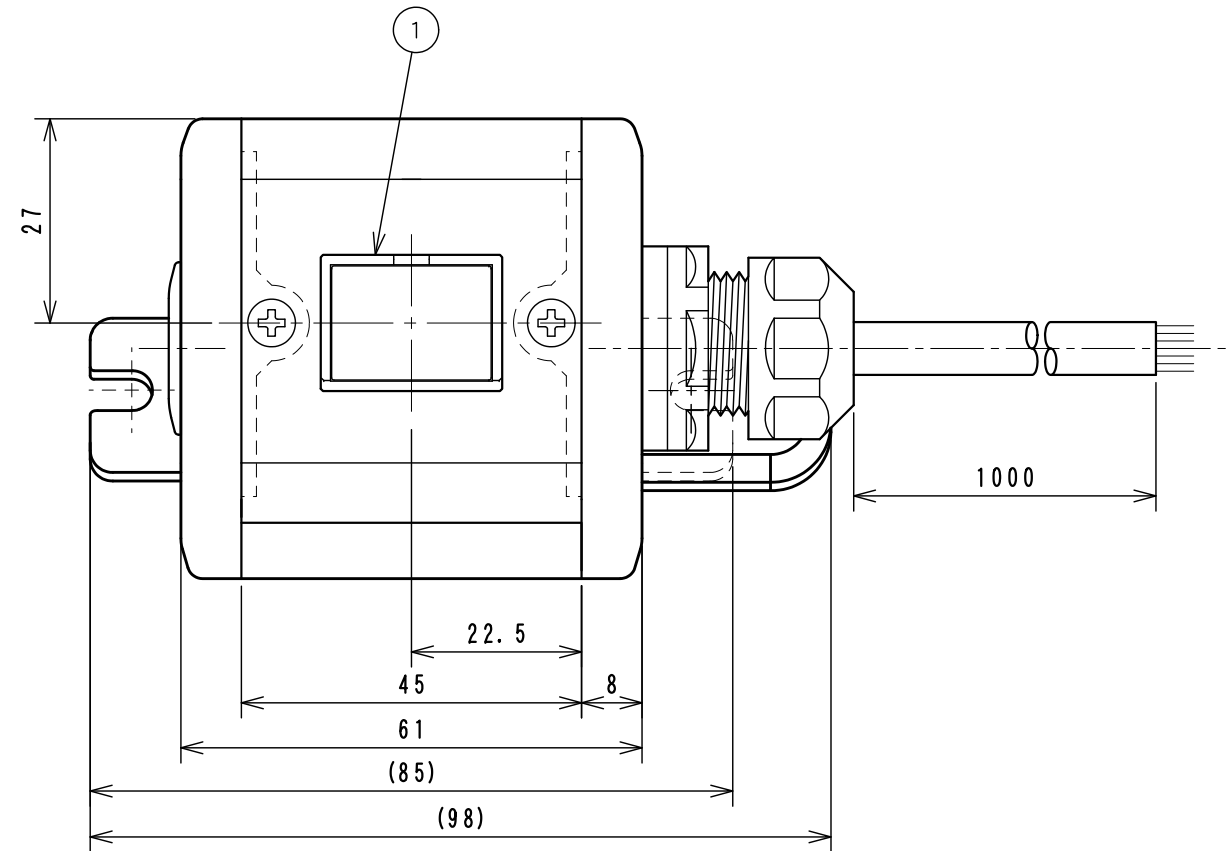
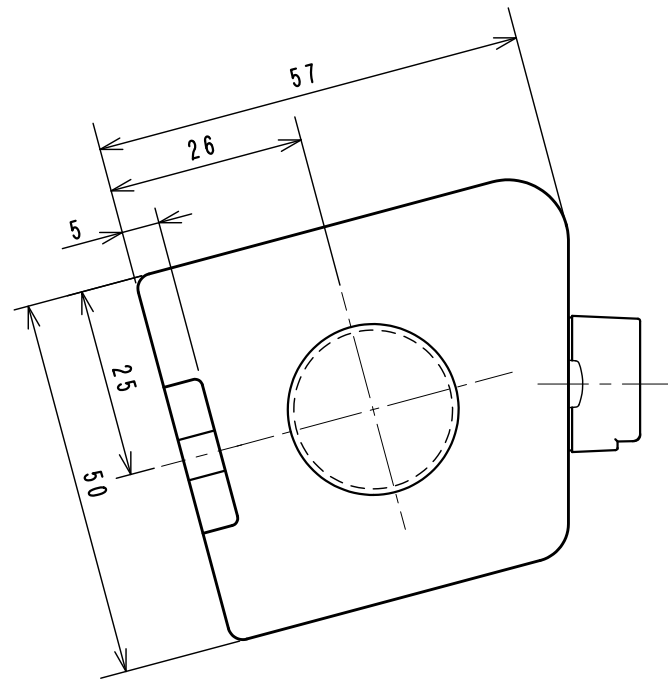

<Associated drawings>
WCW000504-01

Applicable Item No.	NLC-116
	NLC-126

No.	Switch Model No.	Item No.
1	AR16G0T-C1G	C1S-763G

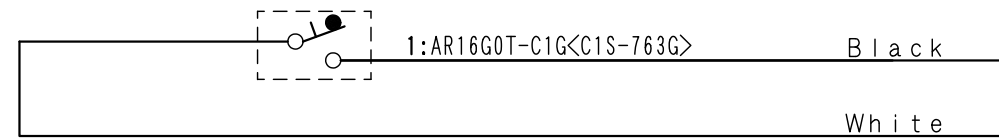

Cable processing detail

