

Item No.	Assembly Name
NLC-218	S-8080D Switch2 (G) /1m 1P+SB

※Attached: S-BOX Support Bracket <D4R-001B>

1	C1S-247G	Pushbutton Switch AR22E0S-11G
2	C1S-232R	Emergency Stop Switch AR22V2R-11R

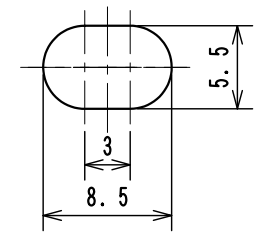
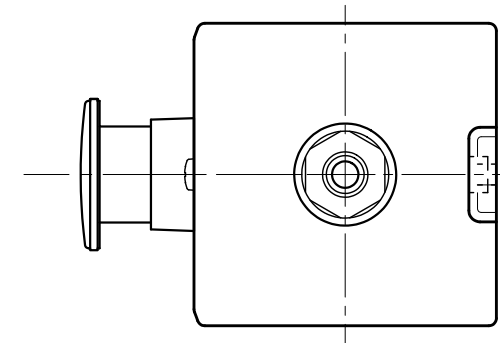
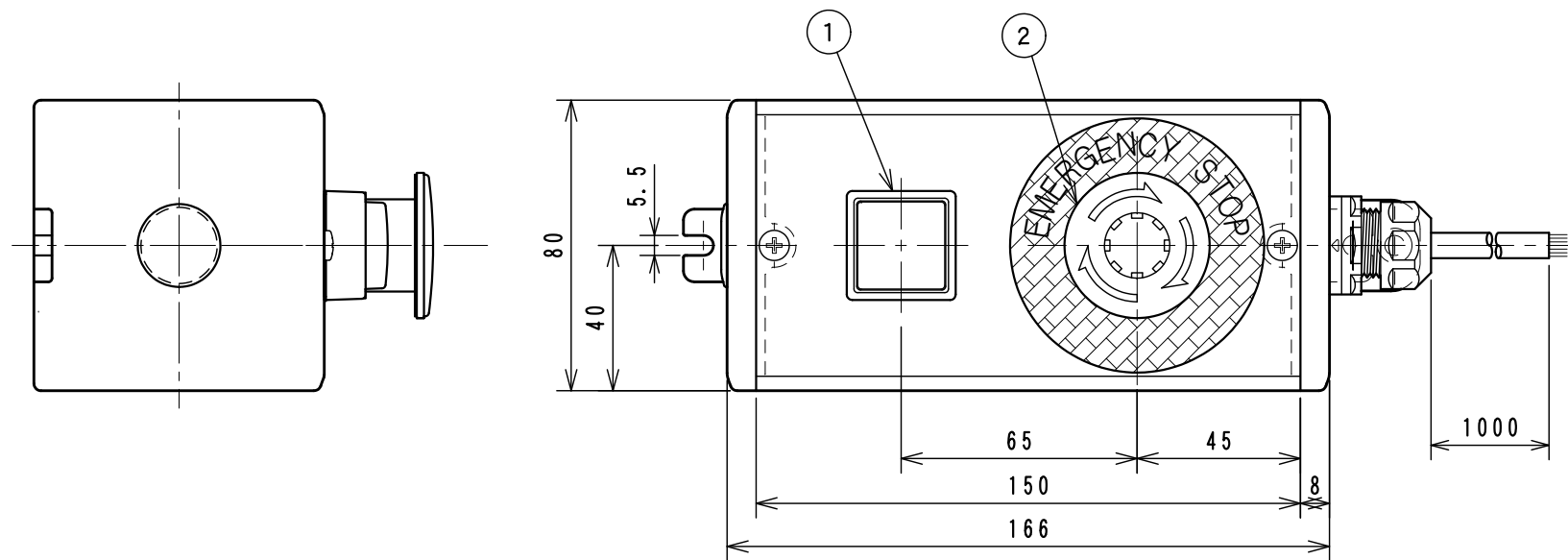

Detail B
Scale 2:1

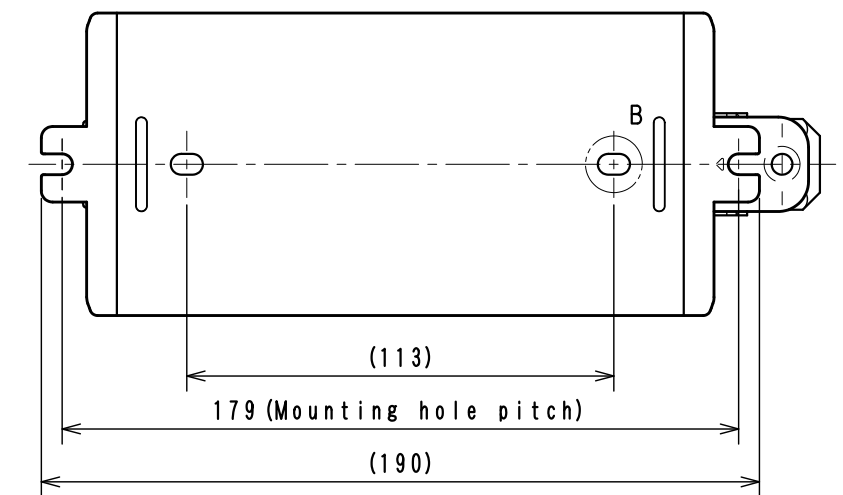
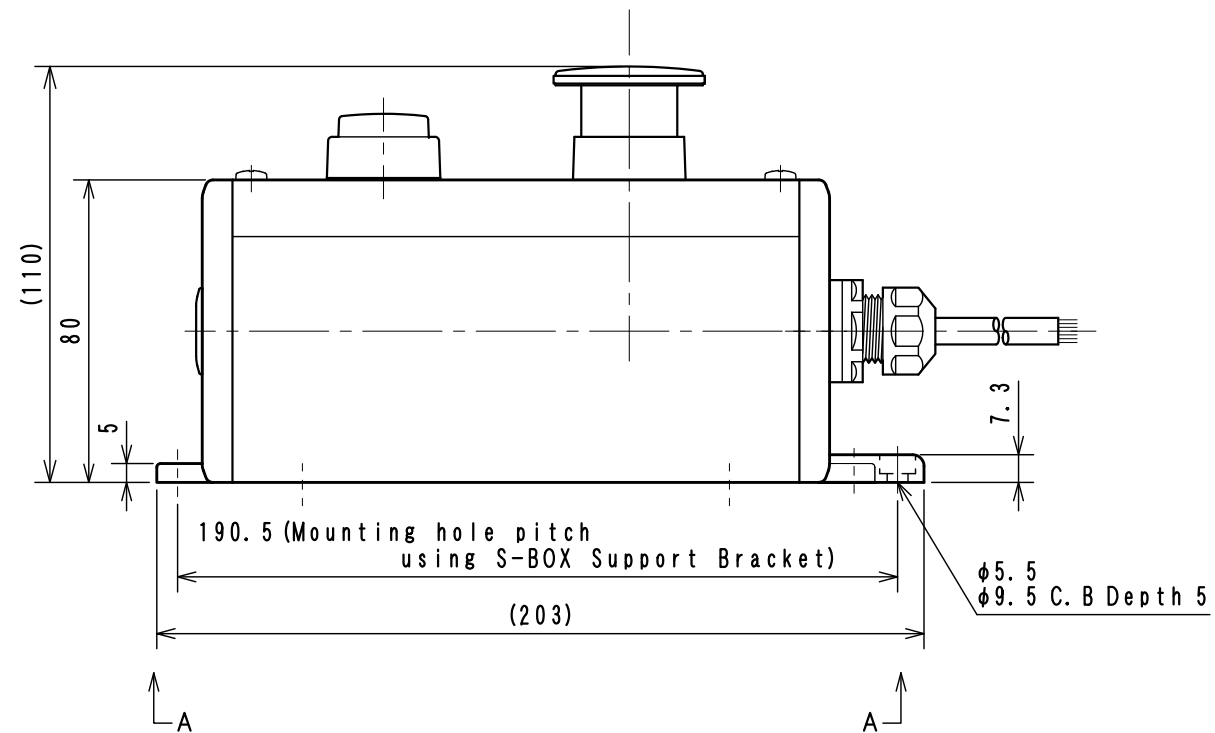

A-A View
Scale 1:2

<Associated drawings>
WCW000547-00

Applicable Item No.	NLC-208
	NLC-218
	NLC-228

No.	Switch Model No.	Item No.
1	AR22E0S-11G	C1S-247G
2	AR22V2R-11R	C1S-232R

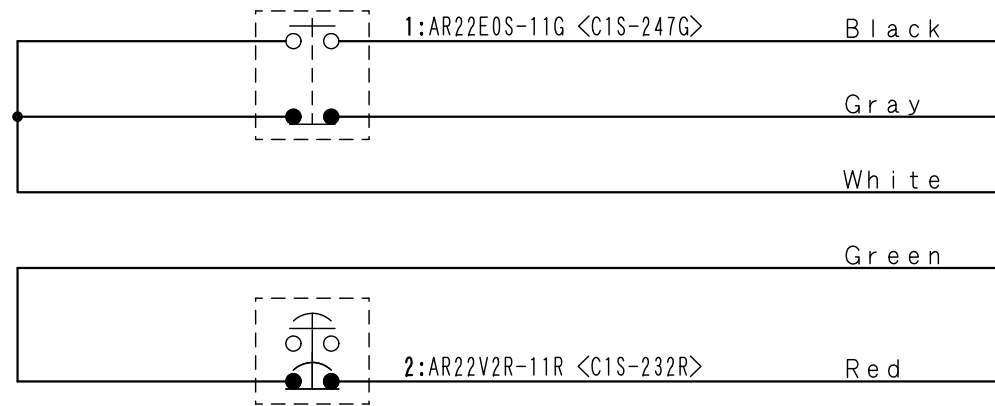

Cable processing detail

