

Item No.	Assembly Name
NLC-21C	S-8080D Switch 2R (GR) /1m 1P+SB

※Attached: S-BOX Support Bracket <D4R-001B>

1	C1S-237G	Pushbutton Switch AR22E0R-11G
2	C1S-237R	Pushbutton Switch AR22E0R-11R

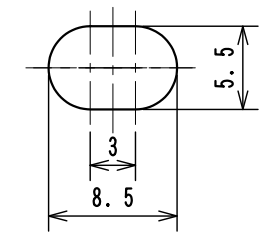
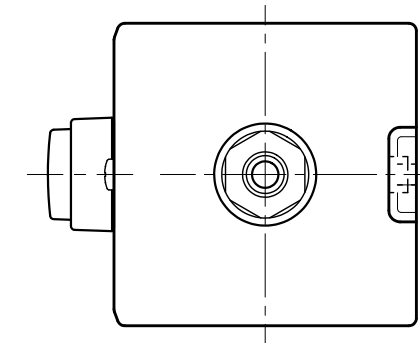
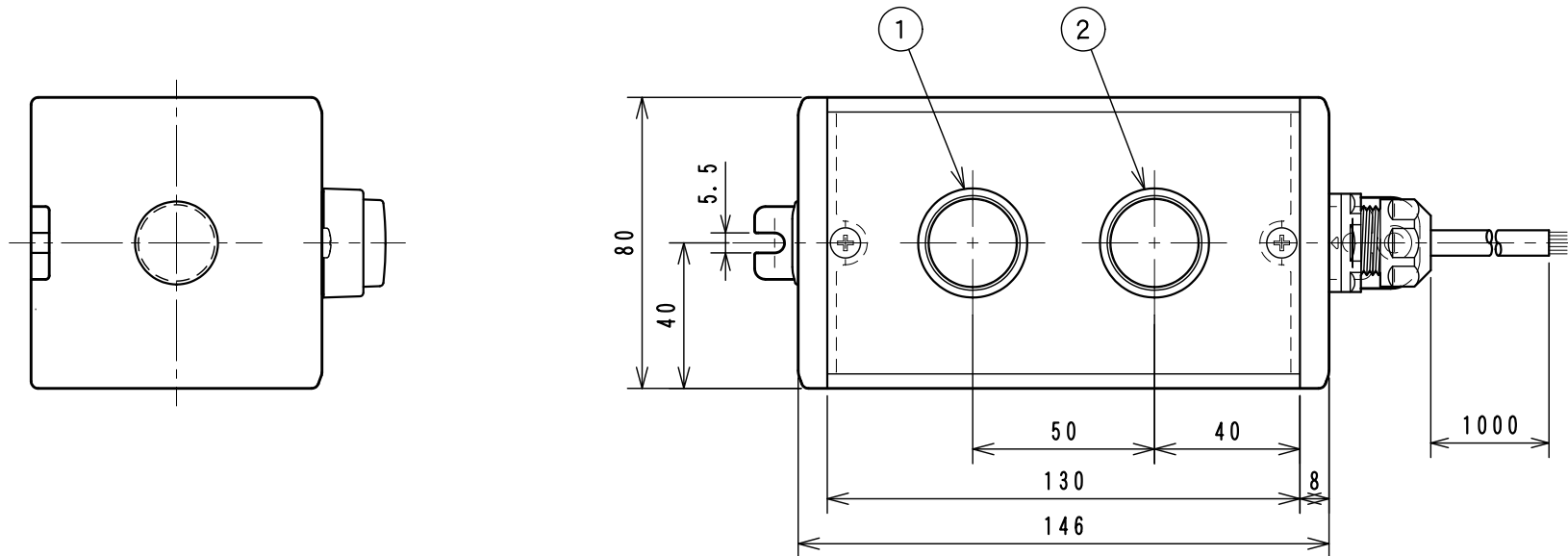

Detail B
Scale 2:1

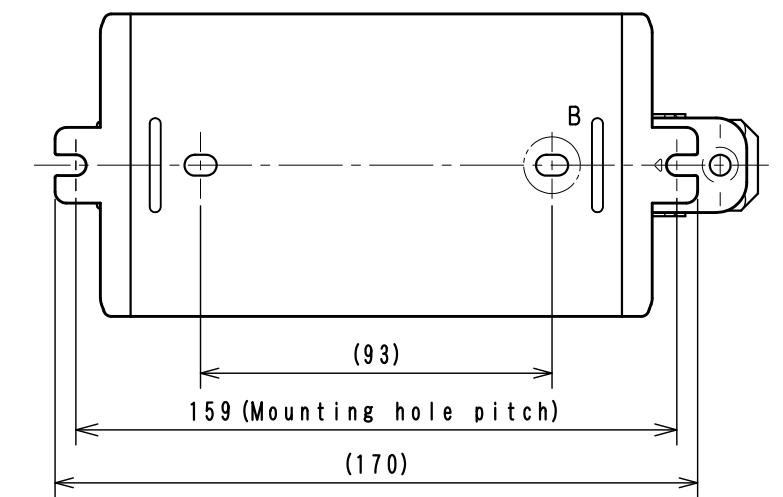
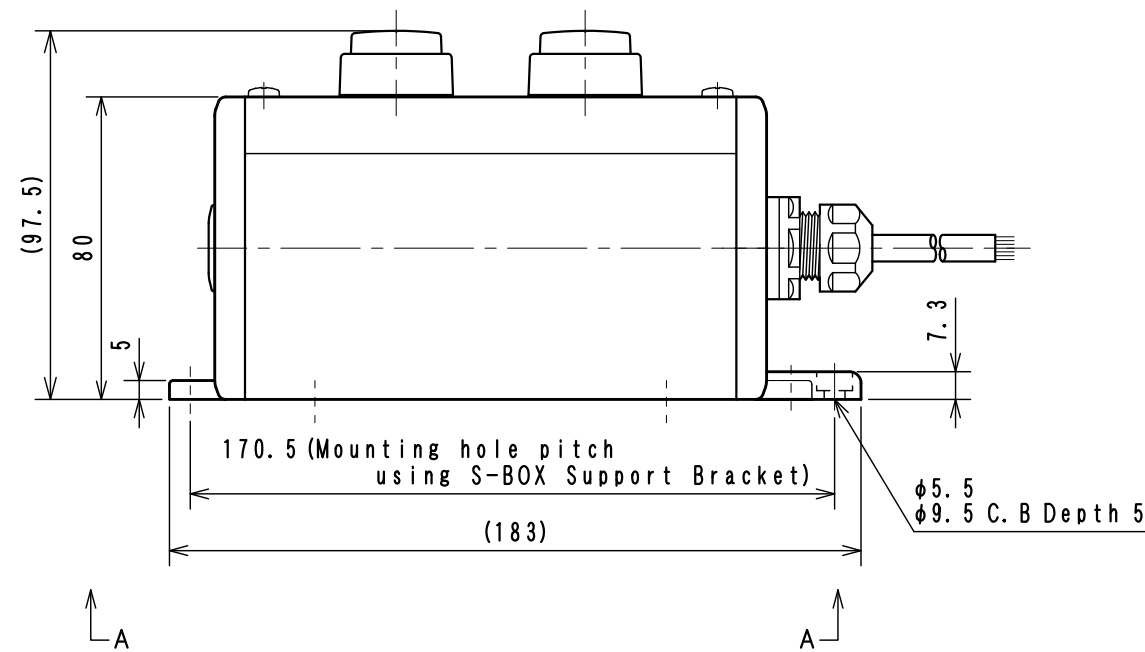

A-A View
Scale 1:2

<Associated drawings>
WCW000551-00

Applicable Item No.	NLC-20C
	NLC-21C
	NLC-22C

No.	Switch Model No.	Item No.
1	AR22E0R-11G	C1S-237G
2	AR22E0R-11R	C1S-237R

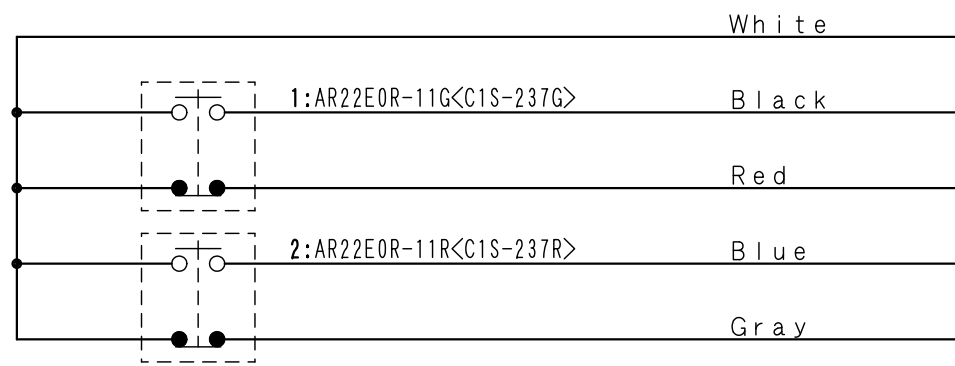

Cable processing detail

