

Item No.	Assembly Name
NLC-222	S-5057D Switch 2 (G) 1m/1P+SB

※Attached: S-BOX Support Bracket <D4R-001B>

1	C1S-763G	Pushbutton Switch AR16G0T-C1G
2	C1S-758R	Emergency Stop Switch AR16V0R-02R

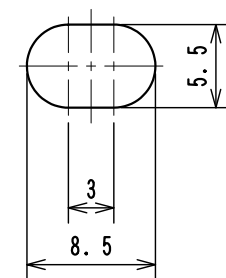
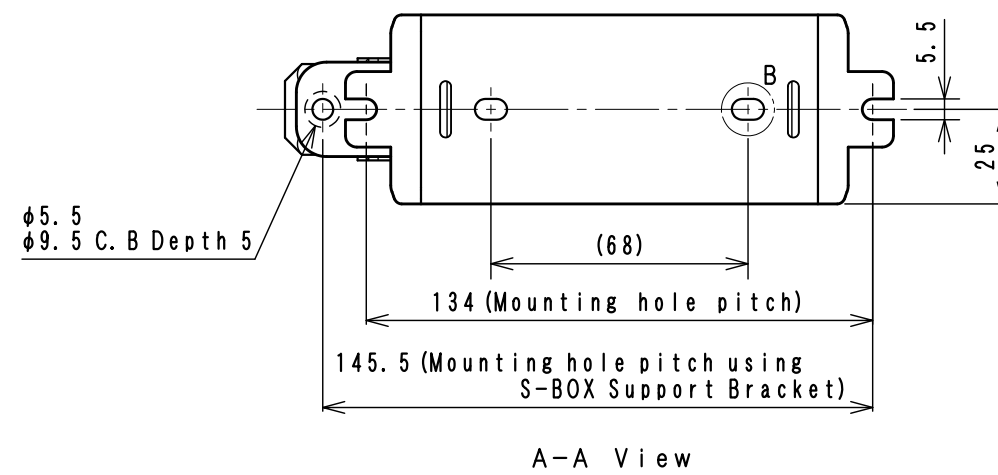
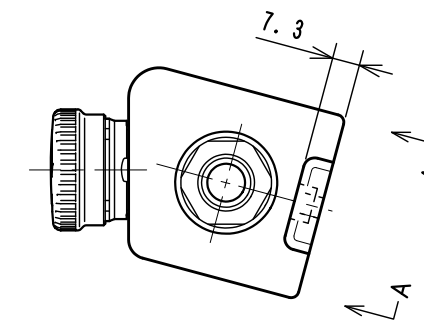
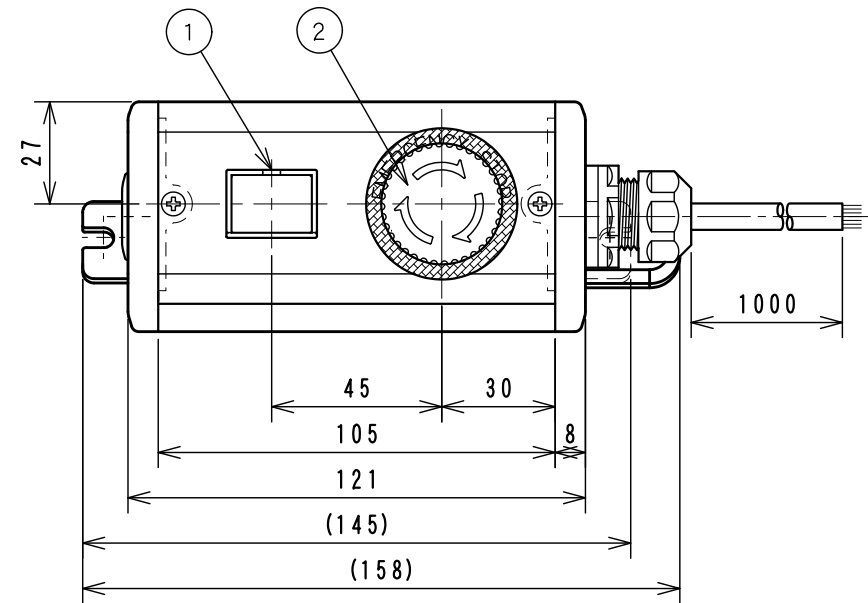
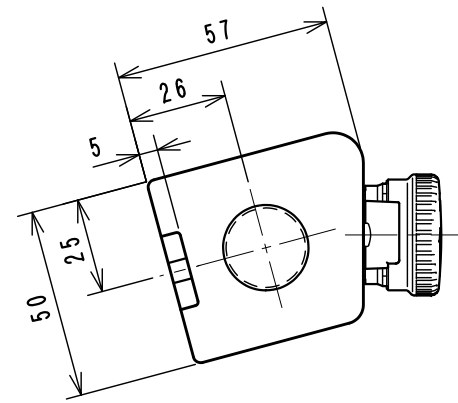

Detail B
Scale 2:1
2 Places

<Associated drawings>
WCW000509-01

Applicable Item No.	NLC-212
	NLC-222

No.	Switch Model No.	Item No.
1	AR16G0T-C1G	C1S-763G
2	AR16V0R-02R	C1S-758R

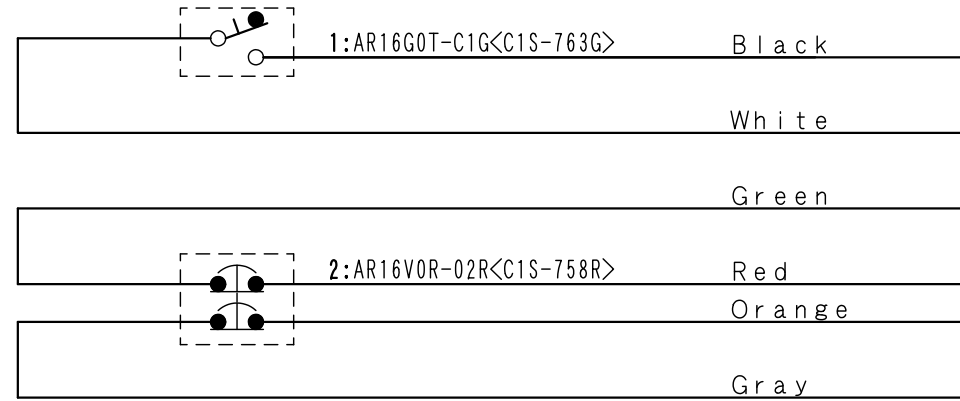

Cable processing detail

