

|          |                                 |
|----------|---------------------------------|
| Item No. | Assembly Name                   |
| NLC-226  | S-5057D Switch 2R (GR) 1m/1P+SB |

※Attached: S-BOX Support Bracket <D4R-001B>

|   |          |                               |
|---|----------|-------------------------------|
| 1 | C1S-764G | Pushbutton Switch AR16E0R-C1G |
| 2 | C1S-764R | Pushbutton Switch AR16E0R-C1R |

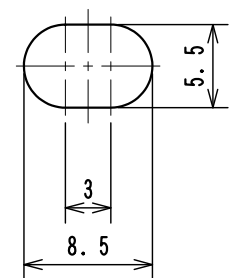
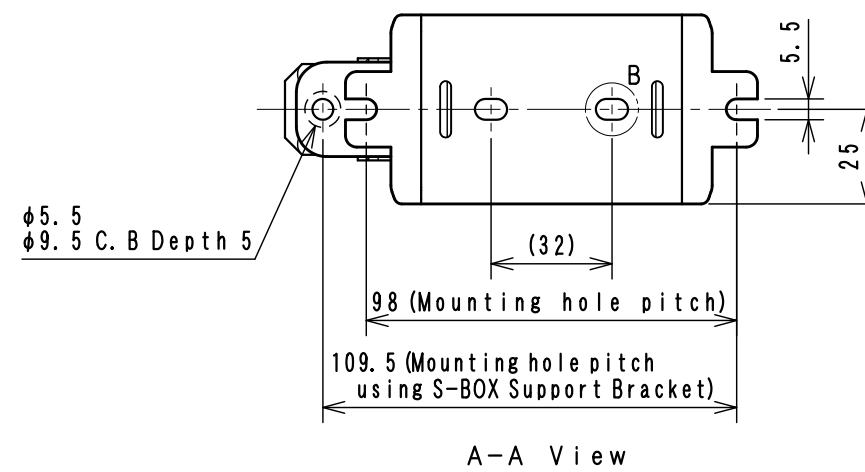
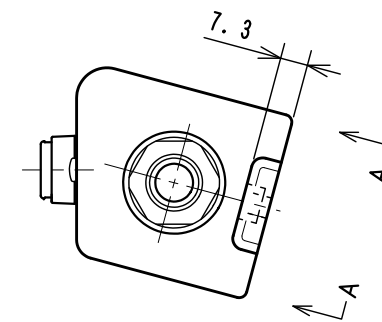
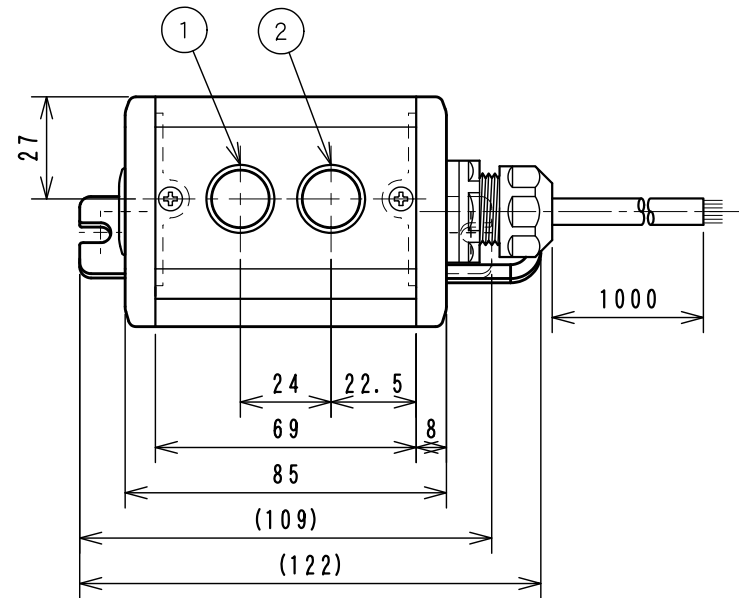
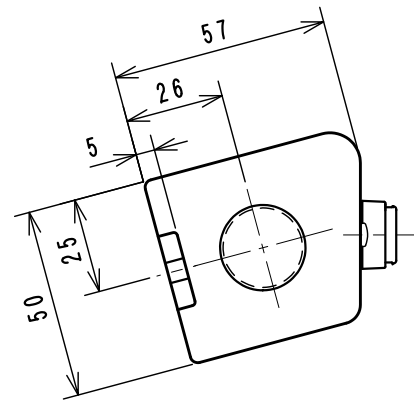

Detail B  
Scale 2:1  
2 Places

<Associated drawings>  
WCW000513-01

|                     |         |
|---------------------|---------|
| Applicable Item No. | NLC-216 |
|                     | NLC-226 |

| No. | Switch Model No. | Item No. |
|-----|------------------|----------|
| 1   | AR16E0R-C1G      | C1S-764G |
| 2   | AR16E0R-C1R      | C1S-764R |

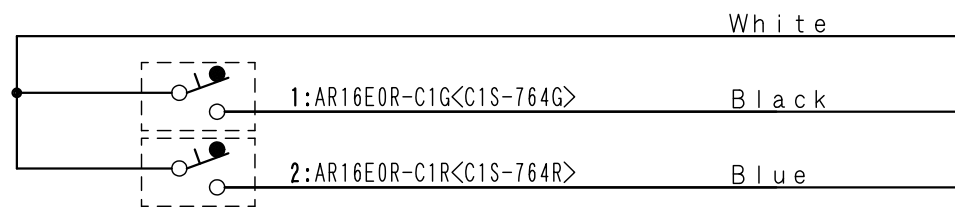

**Cable processing detail**

