

Item No.	Assembly Name
NLC-31C	S-8080D Switch 3 (GR) / 1m 1P+SB

※Attached: S-BOX Support Bracket <D4R-001B>

1	C1S-247G	Pushbutton Switch AR22E0S-11G
2	C1S-247R	Pushbutton Switch AR22E0S-11R
3	C1S-232R	Emergency Stop Switch AR22V2R-11R

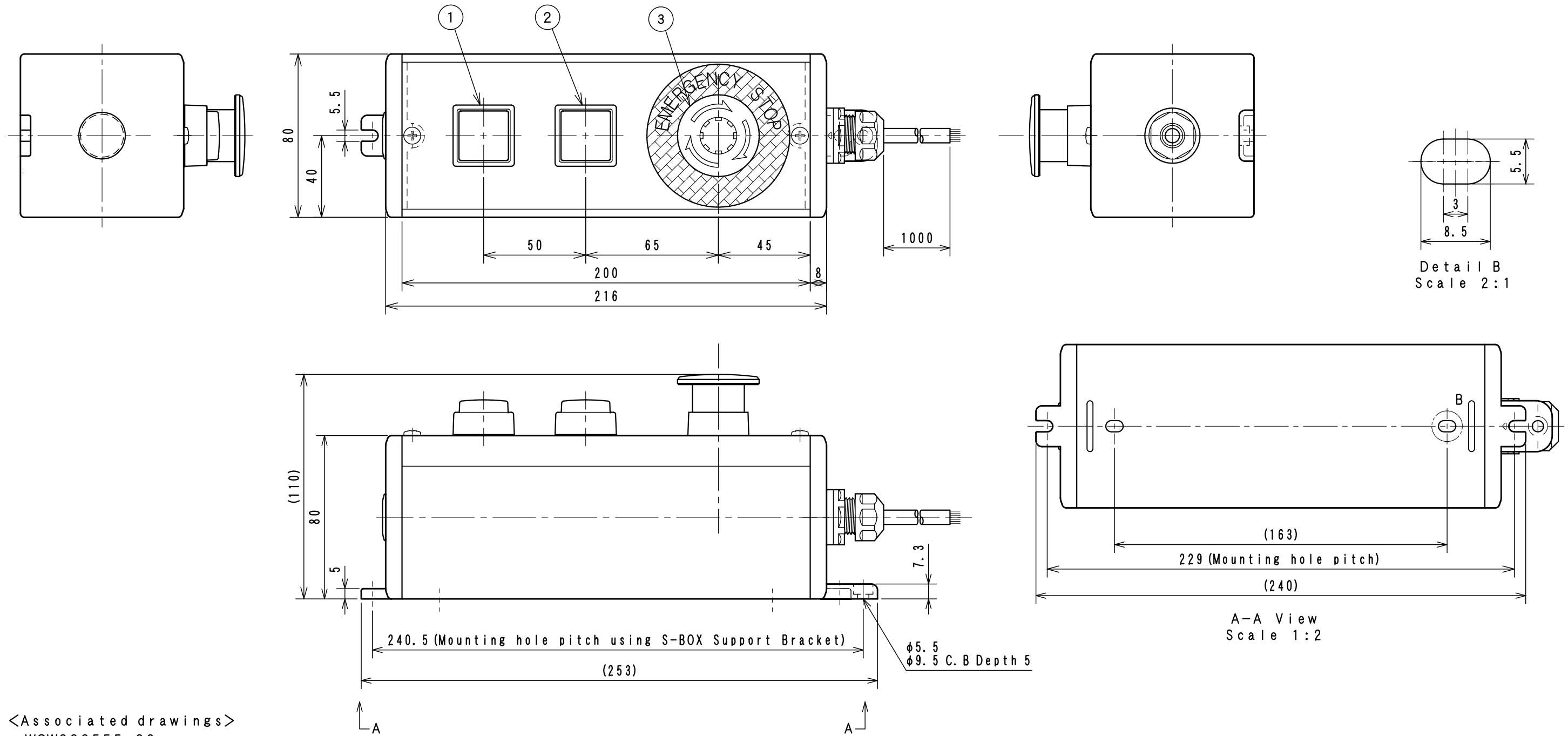

<Associated drawings>  
WCW000555-00

A-A View  
Scale 1:2

Detail B  
Scale 2:1

Applicable Item No.	NLC-30C
	NLC-31C
	NLC-32C

No.	Switch Model No.	Item No.
1	AR22E0S-11G	C1S-247G
2	AR22E0S-11R	C1S-247R
3	AR22V2R-11R	C1S-232R

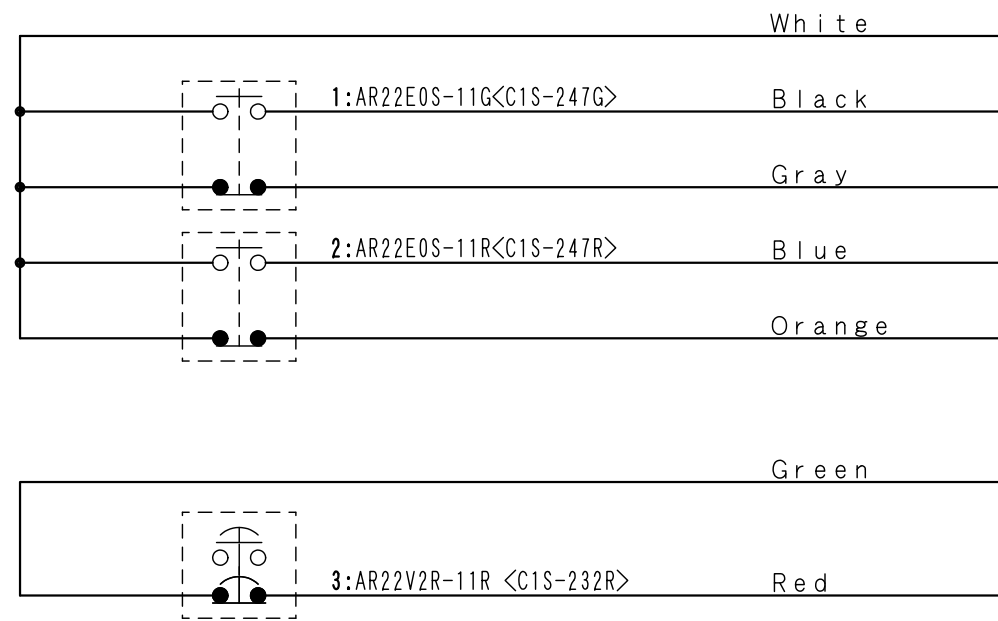

Cable processing detail

