

Item No.	Assembly Name
NLC-31G	S-8080D Switch 3R (GRY) / 1m 1P+SB

※Attached: S-BOX Support Bracket <D4R-001B>

1	C1S-237G	Pushbutton Switch AR22E0R-11G
2	C1S-237R	Pushbutton Switch AR22E0R-11R
3	C1S-237Y	Pushbutton Switch AR22E0R-11Y

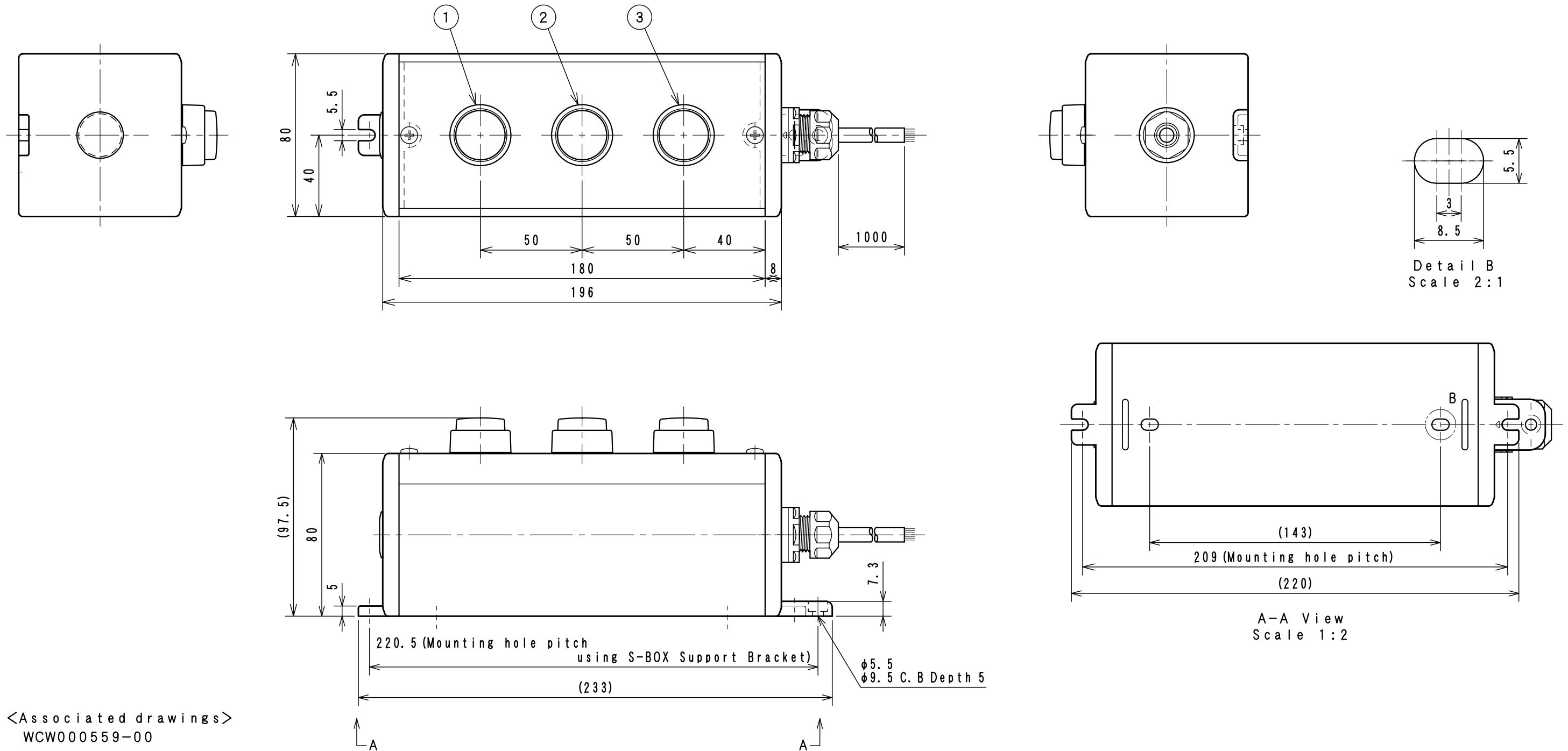

<Associated drawings>
WCW000559-00

Applicable Item No.	NLC-30G
	NLC-31G
	NLC-32G

No.	Switch Model No.	Item No.
1	AR22E0R-11G	C1S-237G
2	AR22E0R-11R	C1S-237R
3	AR22E0R-11Y	C1S-237Y

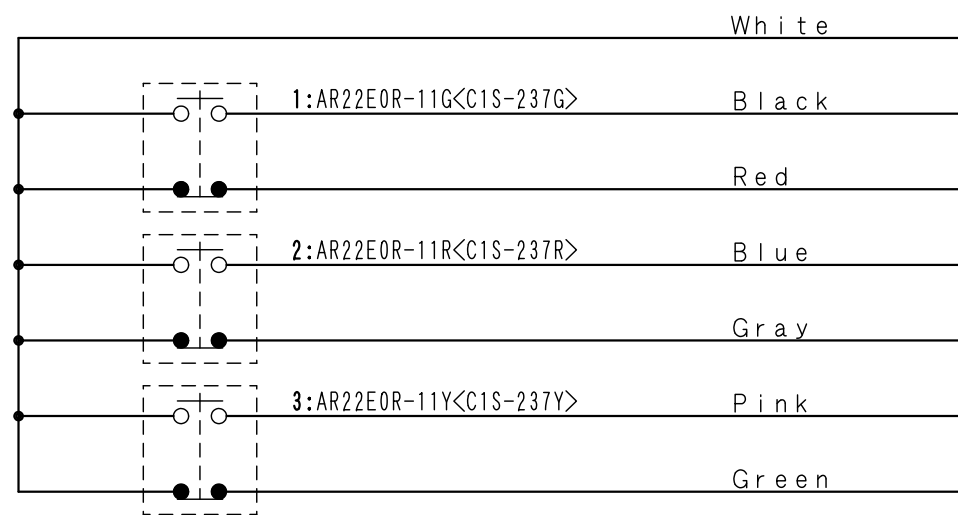

Cable processing detail

