

Item No.	Assembly Name
NLC-326	S-5057D Switch 3S (GRY) 1m/1P+SB

※Attached:S-BOX Support Bracket <D4R-001B>

1	C1S-763G	Pushbutton Switch AR16G0T-C1G
2	C1S-763R	Pushbutton Switch AR16G0T-C1R
3	C1S-763Y	Pushbutton Switch AR16G0T-C1Y

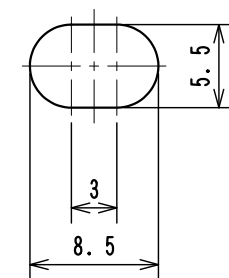
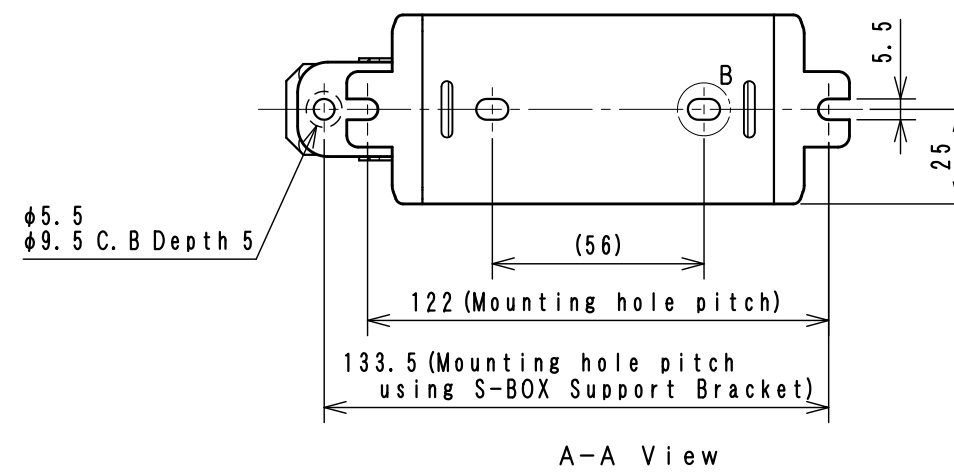
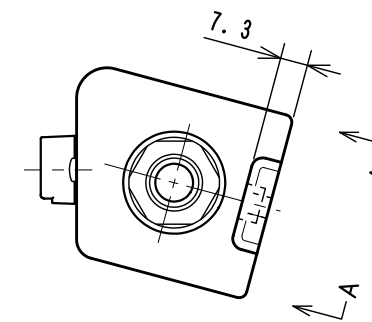
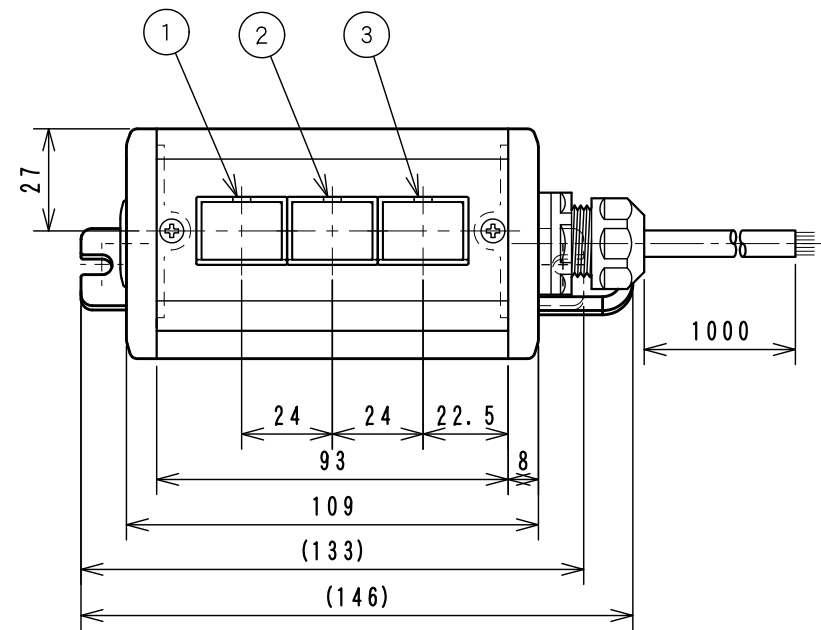
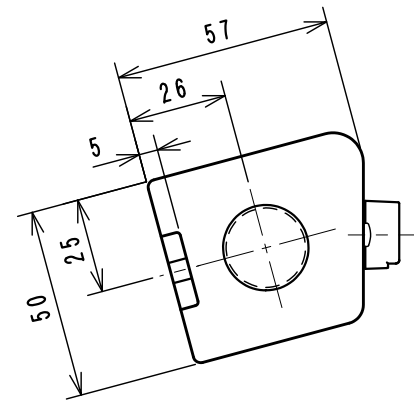

Detail B
Scale 2:1
2 Places

<Associated drawings>
WCW000519-01

Applicable Item No.	NLC-316
	NLC-326

No.	Switch Model No.	Item No.
1	AR16G0T-C1G	C1S-763G
2	AR16G0T-C1R	C1S-763R
3	AR16G0T-C1Y	C1S-763Y

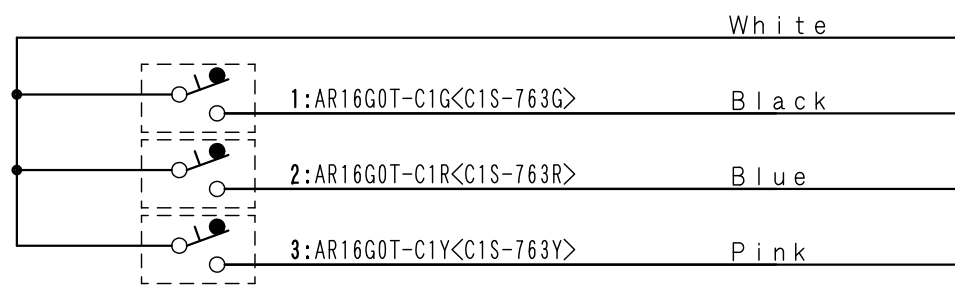

Cable processing detail

